

NGI

AN INTRODUCTION TO INTELLECTUAL PROPERTY

Onur EMUL

**Intellectual Property Institute Luxembourg (IPIL),
NGI TETRA**



IP is all around...

One product – many IP rights

Patents

- Data-processing methods
 - Operating system
 - Operation of user interface
- Touch screen

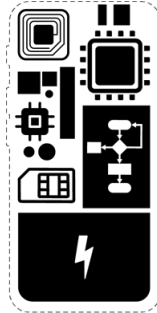

Trade marks

- Brand name
- Mobile jingles
- Application brands



Copyright

- Software
- User manuals
- Ringtones
- Images

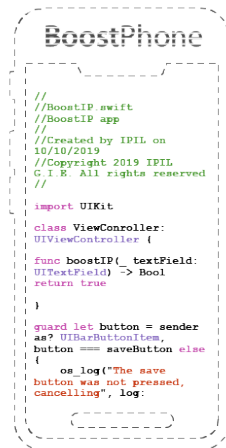

Designs

- Form of overall phone
- Arrangement and shape of buttons
- Position/shape of screen

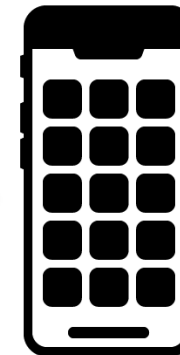

Trade secrets

- Some technical know-how kept "in-house" and not published



Trade marks

Protects signs which **identify** goods and services of a particular **source** and **differentiates** them from the others.

VOLVO

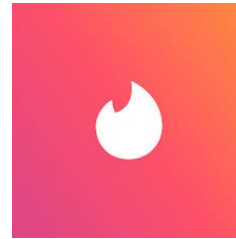
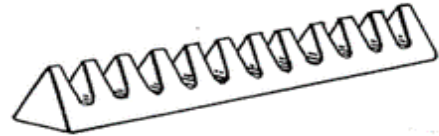

Connecting People



✓ First to file!



✓ A classification system: Nice Classes

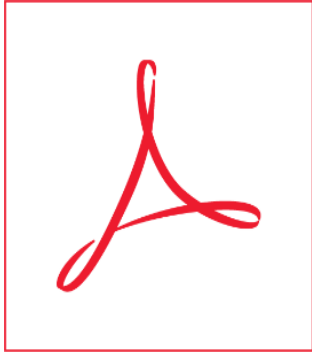

The “Adobe logo” is a registered trade mark owned by Adobe Inc.



The “Bluetooth” word mark and its logo are registered trade marks of Bluetooth SIG, Inc.



The slogan of the Cisco Systems “*Empowering the Internet Generation*” is a registered trade mark.

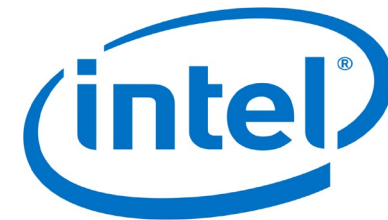

Registered trade mark of Intel Corp.

Designs

Protects **the appearance** of products – not the product itself.

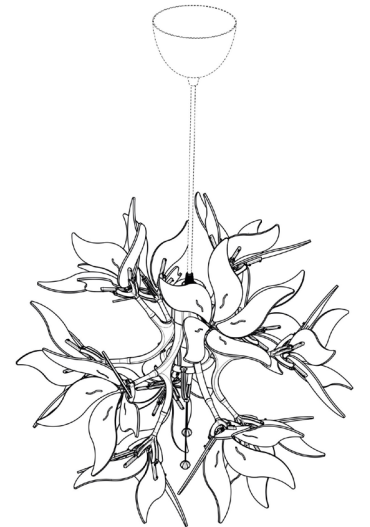
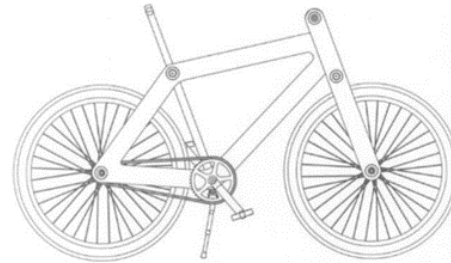

- ✓ **Novel** in design
- ✓ Having an **original / individual character**

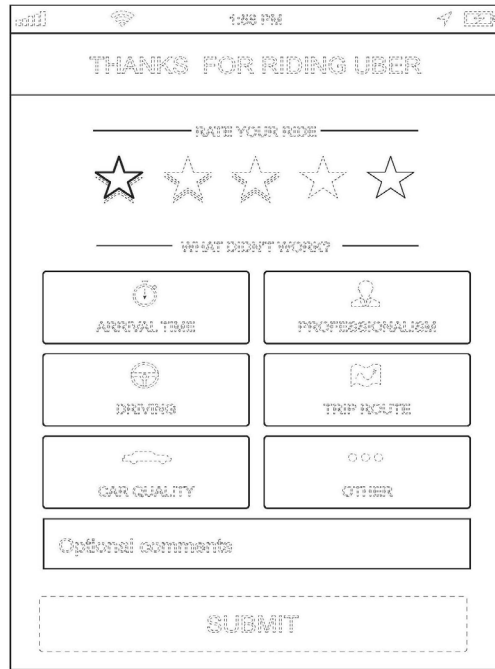

Uber's user interface for driver rating is a registered design



Waldo's hat is a registered design owned by DreamWorks Distribution Ltd.



Graphic interface of a game: registered design by Euro Games Technology Ltd.



Facebook's registered design for an icon/emoji

Patents

Protects **technical inventions / technical solutions to a problem.**

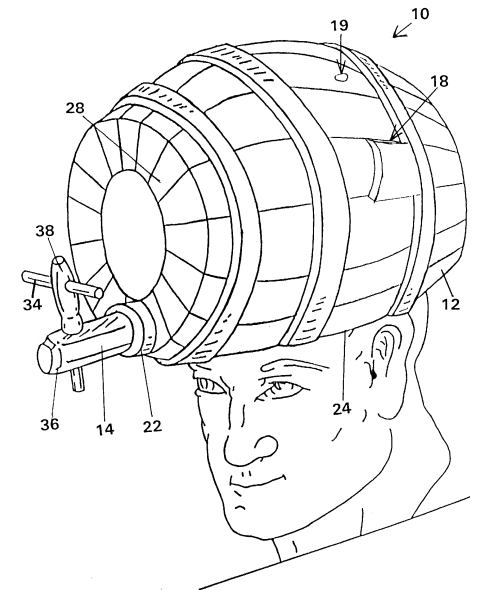
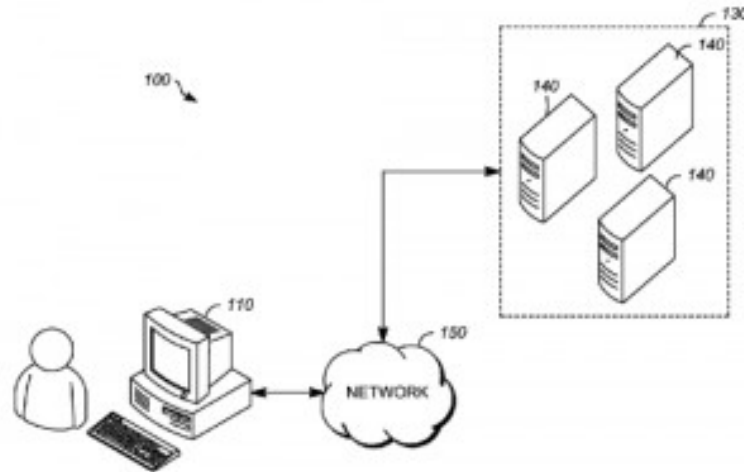
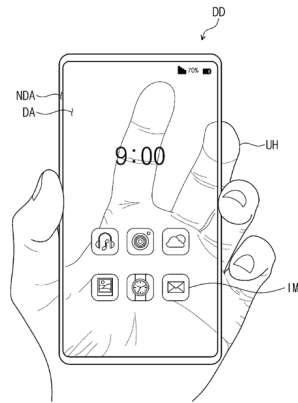
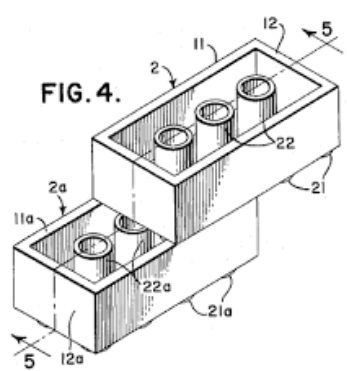

- ✓ **Novel** (new all over the world) → **Patent search?**
- ✓ **Inventive step** (non-obviousness)
- ✓ **Industrial applicability**

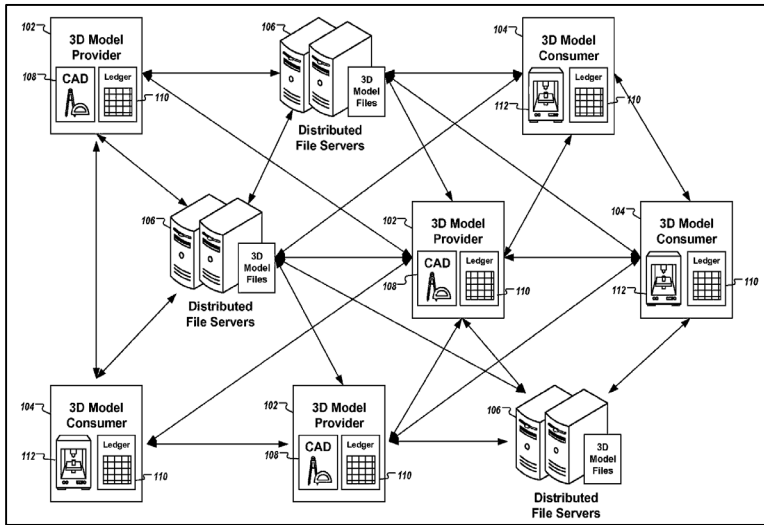

[EP3560137B1](#) Improved blockchain-based method for registration and verification of a file

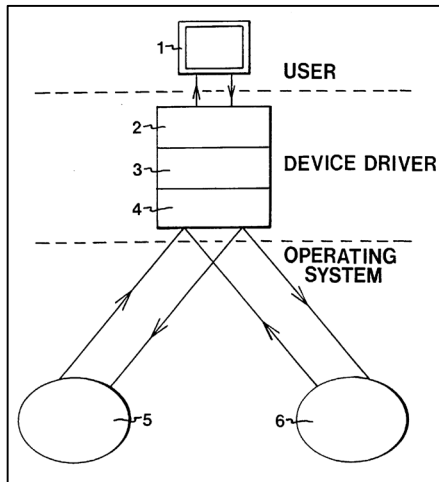

[EP0630497B1](#) Method and computer system for increasing the functionality of a computer program

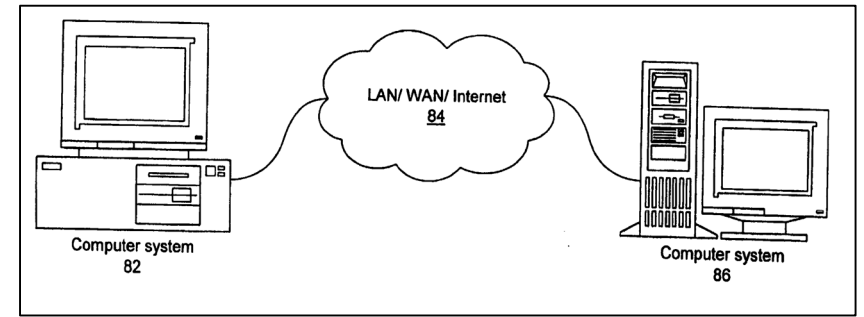

[EP1216441B1](#) Graphical programming system with distributed block diagram execution and user interface display

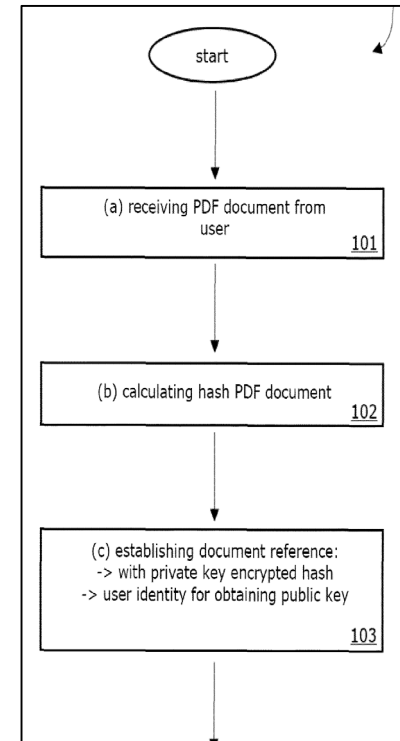

[EP3226165B1](#) Secure 3D model sharing using distributed ledger

Territoriality in IPRs

IPRs are territorial !

Trade marks, designs, patents are protected only in the countries/regions in which you applied for protection.

- ✓ Individual protection
- ✓ Regional protection (TM: EUTM, Designs: RCD, Patents: EP)
- ✓ International application (TM: Madrid Protocol, Designs: Hague Agreement, Patents: PCT)

COSTS ?



Duration and costs

TRADEMARKS:

Heavily depends on the selected route, number of classes, and attorney costs, if any.

EUTM (in EU27):

In one class: 850 €

For the 2nd class: +50 €

Each additional as of the 3rd: +150 €



DESIGNS:

Heavily depends on the selected route, number of designs, and attorney costs, if any.

Community Design (in EU27):

For one design: 350 €

Each additional design up to 10th: +175 €

Each additional design after 11th: +80 €



Duration and costs

PATENTS:

Heavily depends on the selected route, translation and attorney costs.

European Patent (EP):

(for <36 pages* and <16 claims*)

- *Filing*
- *Search report*
- *Designation fee*
- *Examination fee*
- *Grant*

Total: ~5000 € + translation costs

+ Renewal fees

+ Attorney fees



IP SEARCHES !

- ✓ Novelty Search / any prior filers?
- ✓ Avoid infringing third party rights (FTO)
- ✓ Follow up the latest technology and trends
- ✓ Utilise as an idea catalyzer
- ✓ Watching validity of IPRs
- ✓ Networking / identifying partners
- ✓ Monitor competitors and clients
- ✓ Check if someone is infringing your rights (opposition)

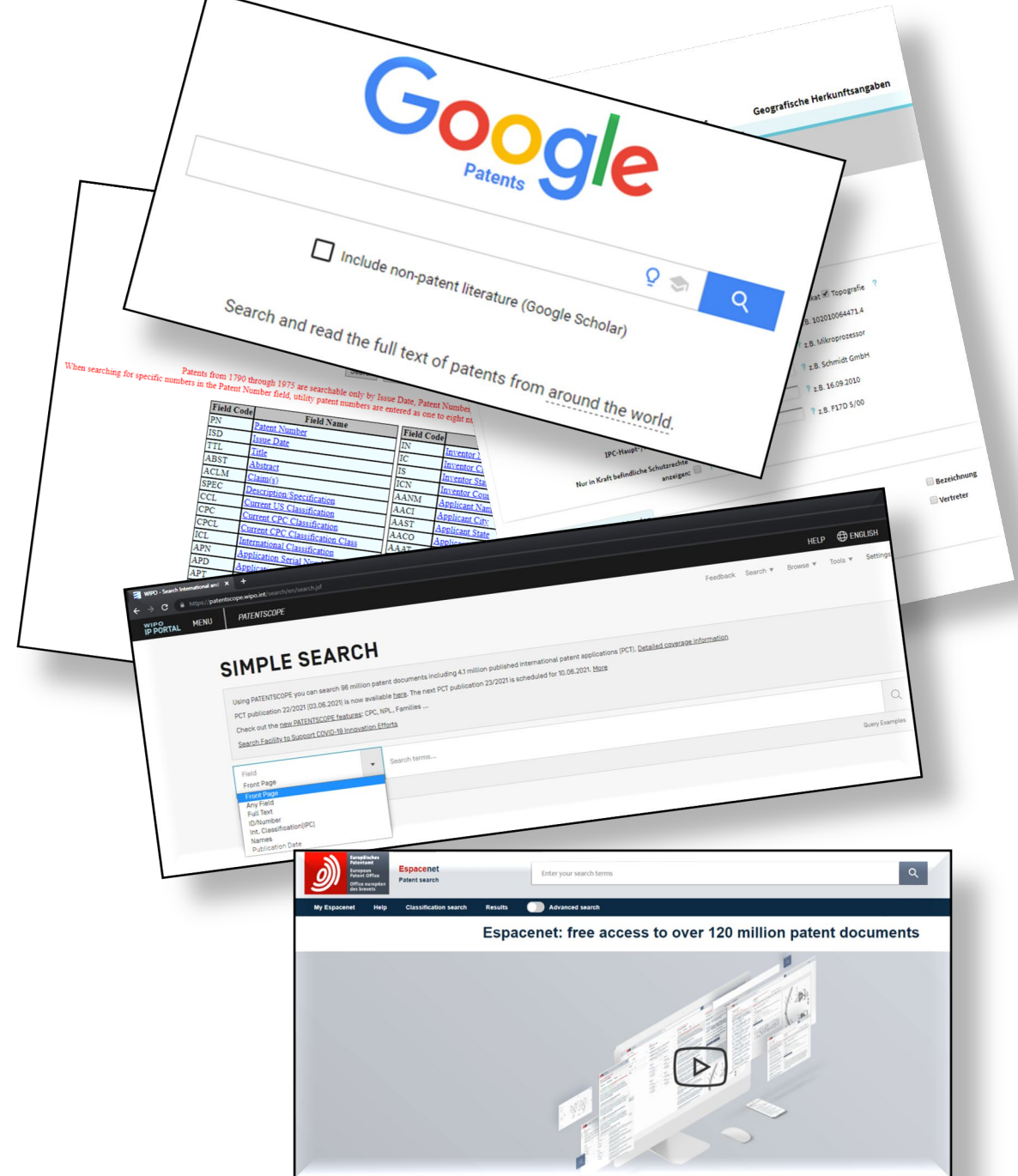

Useful tools

Patents:

<https://www.epo.org/>

<https://www.wipo.int/patents/en/>

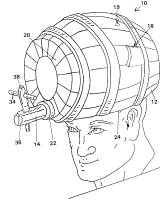

EPO Espacenet: <https://worldwide.espacenet.com>

WIPO PatentScope: <https://patentscope.wipo.int/search/en/search.jsf>

Google Patents: <https://patents.google.com>

Trade marks:

<https://euipo.europa.eu/ohimportal/en/trade-marks>

<https://www.wipo.int/trademarks/en/>



EUIPO eSearchPlus: <https://euipo.europa.eu/eSearch>

EUIPO TMview: www.tmdn.org/tmview/

WIPO Global Brand Database: www.wipo.int/branddb/en

Designs:

<https://euipo.europa.eu/ohimportal/en/designs>

<https://www.wipo.int/designs/en/>



EUIPO eSearchPlus: <https://euipo.europa.eu/eSearch>

EUIPO Designview: www.tmdn.org/tmdsview-web/

WIPO Global Design Database: www.wipo.int/designdb/en/index.jsp

Copyright:

<https://www.wipo.int/copyright/en/>



Free IP support:

<https://iprhelppdesk.eu/>



European
IP Helpdesk

THANKS !



The NGITETRA project has received funding from the European Union's Horizon 2020 Research and Innovation Programme under Grant Agreement No 825147